

REV.	DESCRIPTION	DATE	BY	ECO
A	INITIAL RELEASE	4/19/2007	CT	3573
B	CHANGE OF HARDWARE	8/14/2020	D. ANDERSON	5037

ASSEMBLY NOTES:

- ASSEMBLE HARDWARE AS SHOWN. DISCARD M5 SCREWS AND NUT AND REPLACE WITH 5290.0192 AND 3825.0032.
- DO NOT MOUNT CABLE CLAMPS. PLACE IN SEPARATE BAG.

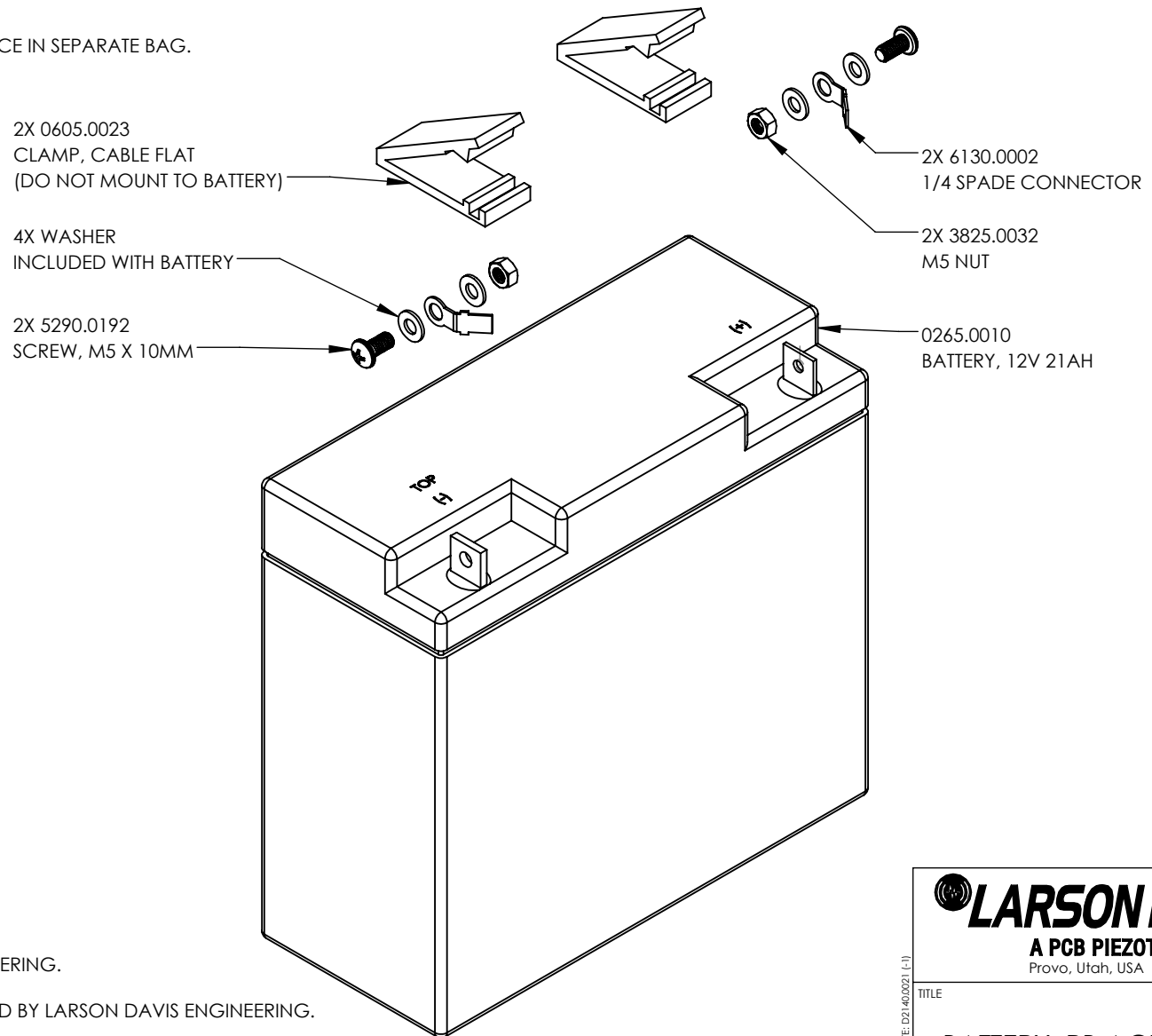

NOTES:

- SEE BOM AS PROVIDED BY PCB ENGINEERING.
- ALL EQUIVALENCIES MUST BE APPROVED BY LARSON DAVIS ENGINEERING.
- ALL COMPONENTS AND PROCESSES MUST BE ROHS COMPLIANT.
- VERIFY INCOMING INSPECTION MARKED WITH AN "X".

PROPRIETARY AND CONFIDENTIAL THIS DOCUMENT, SUBMITTED IN CONFIDENCE, CONTAINS PROPRIETARY INFORMATION WHICH SHALL NOT BE REPRODUCED OR TRANSFERRED TO OTHER DOCUMENTS OR DISCLOSED TO OTHERS OR USED FOR ANY OTHER PURPOSE WITHOUT THE WRITTEN PERMISSION OF PCB PIEZOTRONICS, INC.
 COPYRIGHT © PCB PIEZOTRONICS, INC. FILE NAME: BAT011 BATTERY, PB ACID 12V, 21 AH W-SPADE CONN

AUTHOR
D. ANDERSON
DATE
4/19/2007

LARSON DAVIS
 A PCB PIEZOTRONICS DIV.
 Provo, Utah, USA (801) 375-0177

TEMPLATE: D21-40.0001 (-)

TITLE
BATTERY, PB ACID 12V, 21 AH W/SPADE CONN

SIZE A	NUMBER BAT011	REV. B
SCALE 1:2	SHEET 1 OF 1	