

REV.	DESCRIPTION	DATE	BY	ECO
B		8.11.2006	LH	3438
C	M1145.0005 WAS 1145.0005	2/26/2007	CT	3509
D	ADDED S770.22B AND MOVED ASSEMBLY OF INSULATOR	8/26/2011	LH	4013
E	INCLUDED 3900.0075 O-RING WITH CHANGE TO M426.02 ADAPTOR. CORRECTED ASSEMBLY INSTRUCTIONS	9/8/2016	DA	4466
F	ADDED PRMLxT2C	1/23/2020	D. WEBSTER	4942
G	RE-ORDERED ASSEMBLY INSTRUCTIONS	10/21/2020	D. WILDING	5061

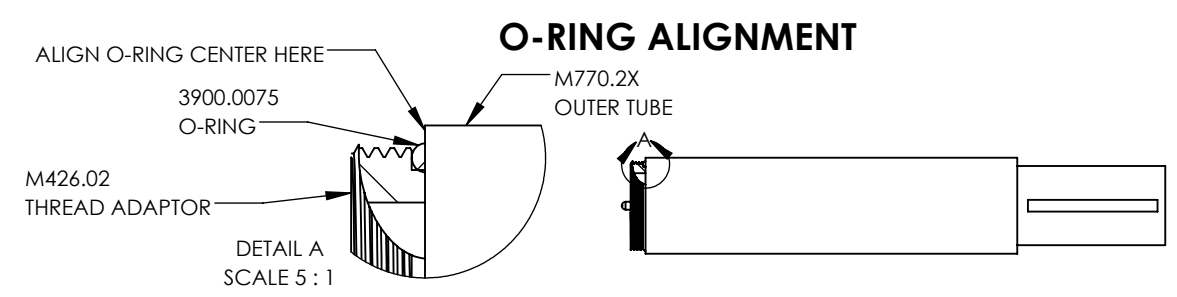
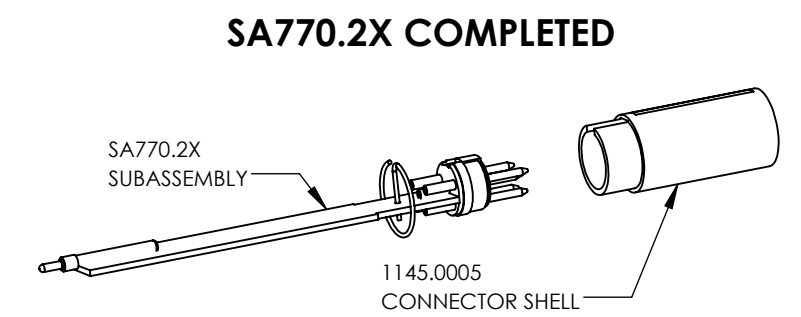
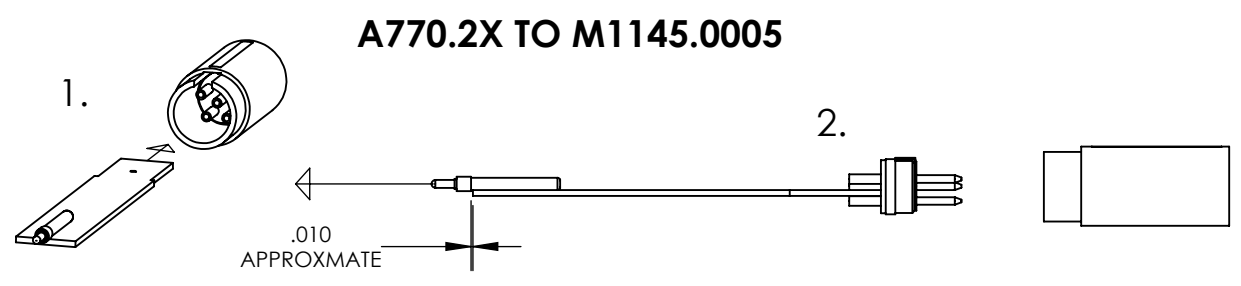
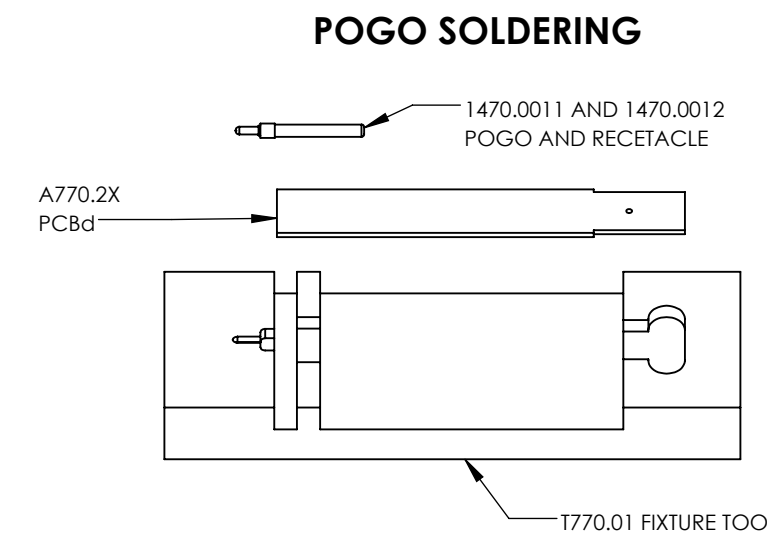
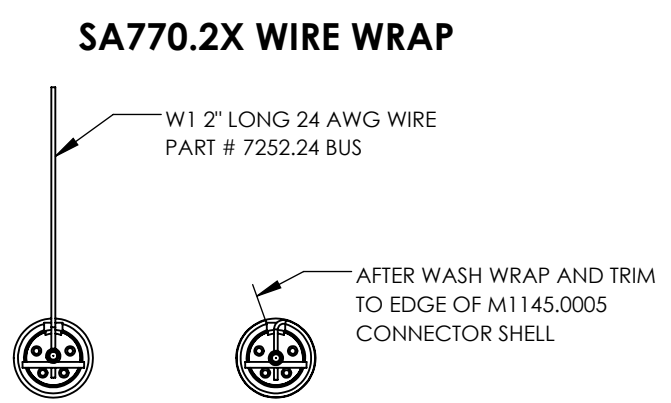
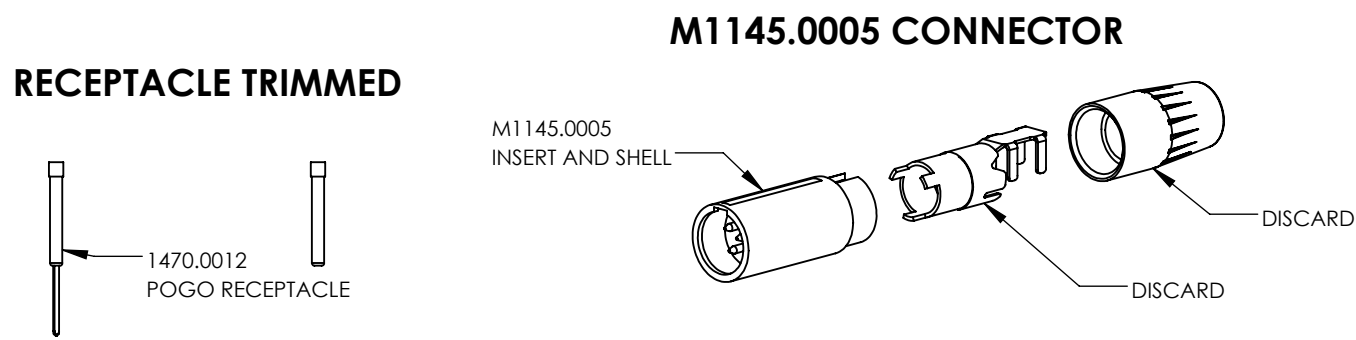

## SA770.2X ASSEMBLY INSTRUCTIONS

- TRIM EXCESS OFF 1470.0012 POGO RECEPTACLE (SEE RECEPTACLE TRIMMED).
  - PRESS 1470.0011 POGO INTO 1470.0012 POGO RECEPTACLE.
  - USING THE T770.01 FIXTURE, POGO ASSEMBLY, AND A770.2X SOLDER THE POGO ASSEMBLY TO THE PCBd. BE SURE TO PUSH THE BOARD AS CLOSE AS POSSIBLE TO THE POGO END OF THE TOOL (SEE POGO SOLDERING).
  - DISASSEMBLE THE M1145.0005 AND RETAIN THE INSERT AND SHELL (SEE M1145.0005 CONNECTOR).
  - TAKE THE REMAINING M1145.0005 INSERT AND SHELL AND PUSH THE A770.2X INTO THE SHELL ALIGNING THE 5 PINS AROUND THE BOARD(1.). PULL OUT THE PCBd WITH THE M1145.0005 INSERT ON IT(2.). ENSURE THE INSERT AND PCBd DO NOT HAVE A GAP BETWEEN THEM. SOLDER THE INSERT INTO PLACE(SEE SA770.2X TO M1145.0005).
  - CUT THE 7252.24 BUS WIRE TO SIZE AND SOLDER TO THE A770.2X PCBd (SEE SA770.2X WIRE WRAP).
  - REMOVE THE M1145.0005 SHELL AND PLACE INTO AN ANTISTATIC BAG FOR REASSEMBLY AFTER THE BOARD CLEANING.
  - CLEAN PCBd ASSEMBLY ACCORDING TO D0001.7034 BOARD CLEANING INSTRUCTIONS.
- USING THE M1145.0005 CONNECTOR SHELL, WRAP THE 7252.24 BUS WIRE AROUND IT AS TIGHTLY AS POSSIBLE (SEE SA770.02X WIRE WRAP).
  - TRIM THE EXCESS M1145.0005 BUS WIRE TO THE SLOT OF THE M1145.005 CONNECTOR SHELL (SEE SA770.02X WIRE WRAP).
  - PERFORM BOARD TESTS ACCORDING TO D0001.8294

## S770.2X ASSEMBLY INSTRUCTIONS

- INSERT THE SA770.2X ASSEMBLY INTO THE M770.2X OUTER TUBE AND TIGHTEN IT DOWN WITH THE TORQUE WRENCH TO 17 IN-LBS.
- PUSH THE M770.30 ONTO THE POGO.
- PLACE 3900.0075 O-RING INTO GROOVE ON M426.02 THREAD ADAPTOR. ENSURE THE O-RING IS NOT TWISTED ONCE PLACED ON THE THREAD ADAPTOR.
- SCREW THE M426.02 THREAD ADAPTOR INTO THE OUTER TUBE, LARGE END ON THE OUTSIDE. ALIGN THE O-RING ON THE THREAD ADAPTOR TO BE ABOUT HALF WAY DOWN INTO THE M770.2X OUTER TUBE WITHOUT LETTING THE THREAD ADAPTOR BOTTOM OUT. USE A PIECE OF THICK RUBBER FOR THIS (SEE O-RING ALIGNMENT).
- LOCK BNC AND THREAD ADAPTOR THREADS WITH LOCTITE 222 (PURPLE).
- TIGHTEN THREAD ADAPTOR HAND TIGHT.
- PERFORM METCAL TEST ICP PREAMP.

- Notes:
- All equivalencies must be approved by PCB Engineering.
  - All components and processes must be ROHS compliant.
  - First article to be approved by PCB Engineering.

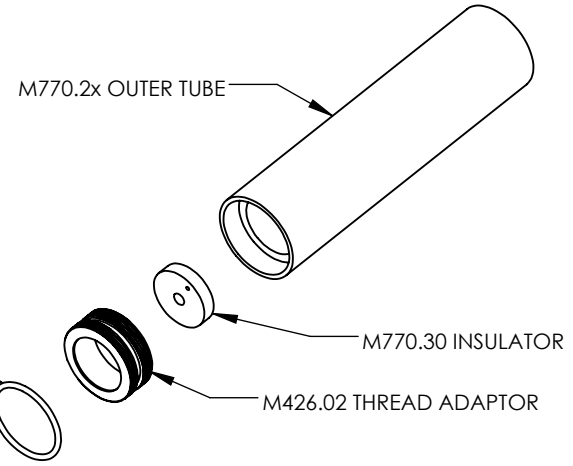
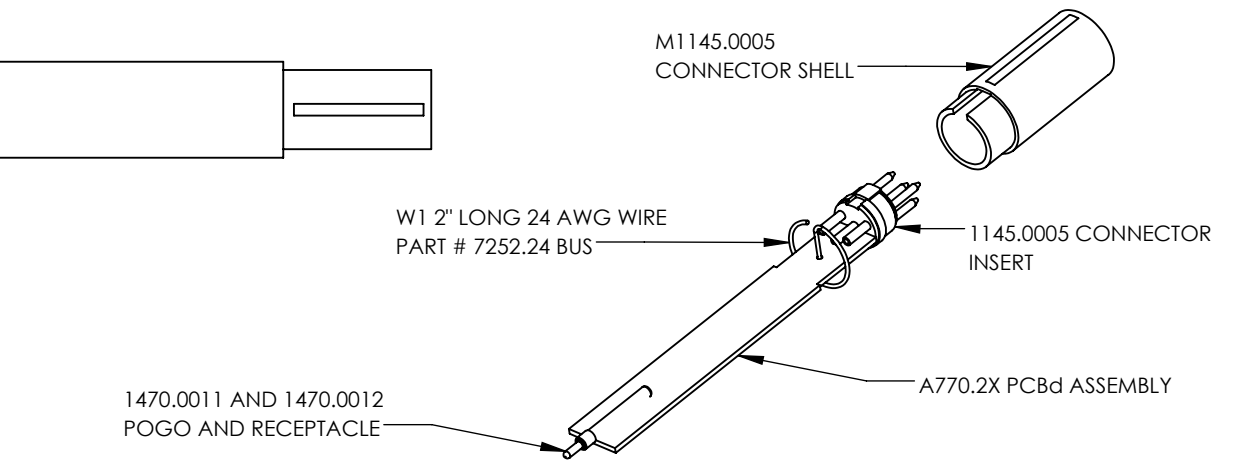

PRODUCT	SUBASSEMBLY	PCBd ASSMBLY	OUTER TUBE
PRMLxT1	S770.21	A770.21	M770.21
PRMLxT1L	S770.21L	A770.21L	M770.21L
PRMLxT2	S770.22	A770.22	M770.22
PRMLxT2L	S770.22L	A770.22L	M770.22L
PRMLxT2B	S770.22B	A770.22B	M770.22B
PRMLxT2C	S770.22C	A770.22C	M770.22C

PROPRIETARY AND CONFIDENTIAL THIS DOCUMENT, SUBMITTED IN CONFIDENCE, CONTAINS PROPRIETARY INFORMATION WHICH SHALL NOT BE REPRODUCED OR TRANSFERRED TO OTHER DOCUMENTS OR DISCLOSED TO OTHERS OR USED FOR ANY OTHER PURPOSE WITHOUT THE WRITTEN PERMISSION OF PCB PIEZOTRONICS, INC.

COPYRIGHT © PCB PIEZOTRONICS, INC. FILE NAME: S770.2X LxT Preamp Assembly

AUTHOR  
D. ANDERSON

DATE  
9/9/2016

**PCB PIEZOTRONICS™**  
Provo, Utah, USA (801) 375-0177

TITLE  
**LxT Preamp Assembly**

SCALE 1:1

REV. **G**

SHEET 1 OF 1